

TOP VIEW

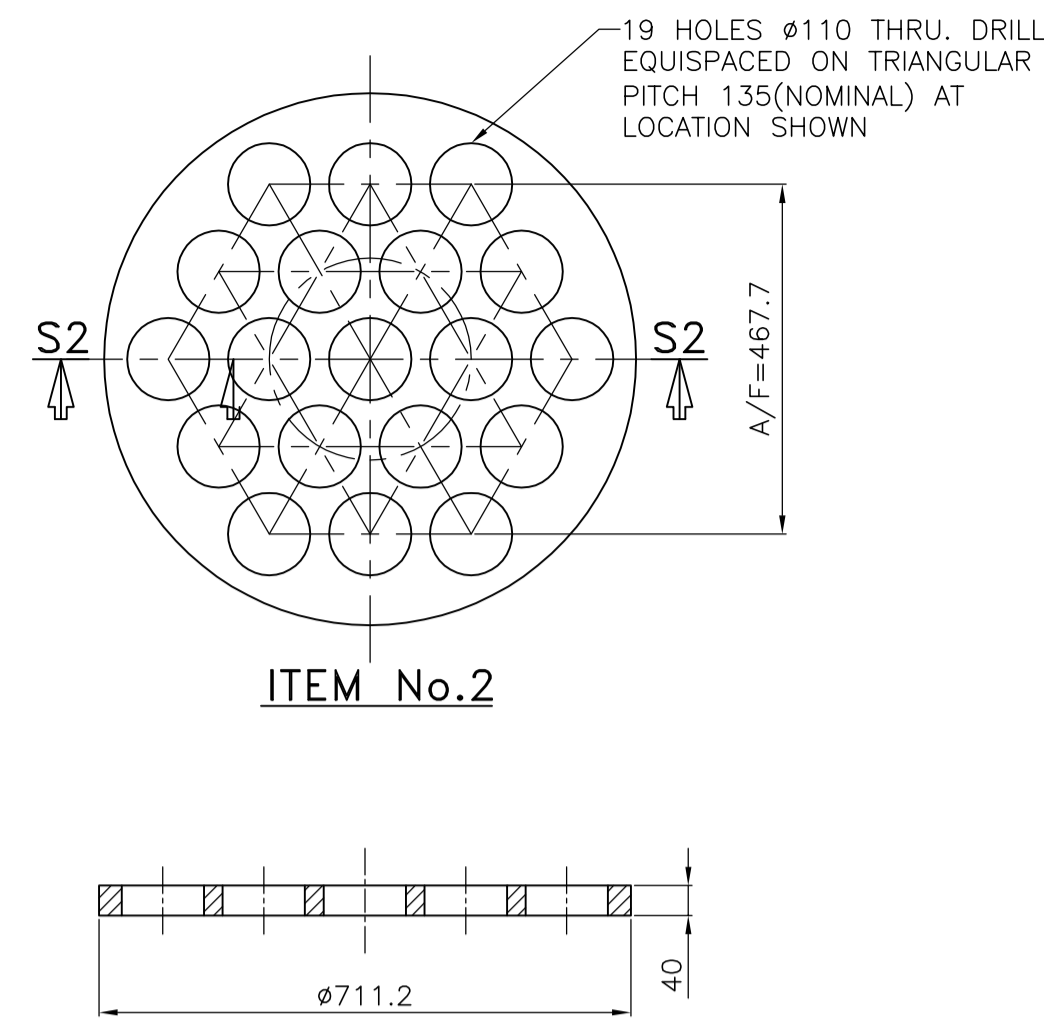

ITEM No.2

SECTION-S2S2

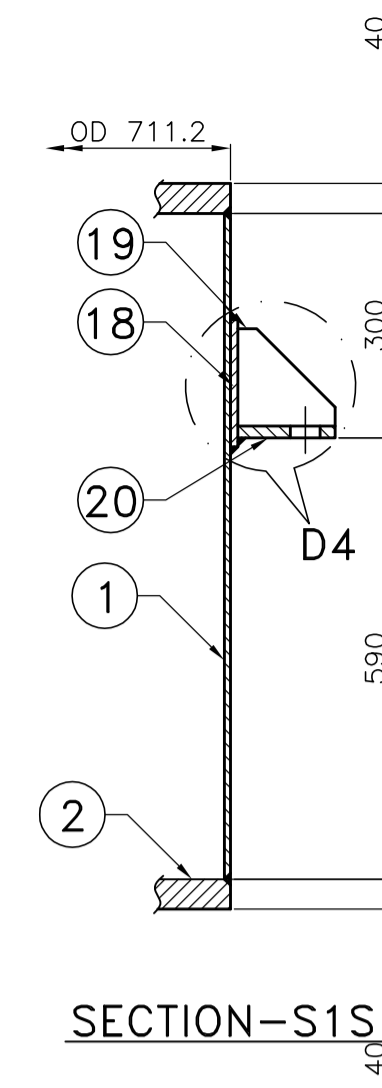

SECTION-S1S1

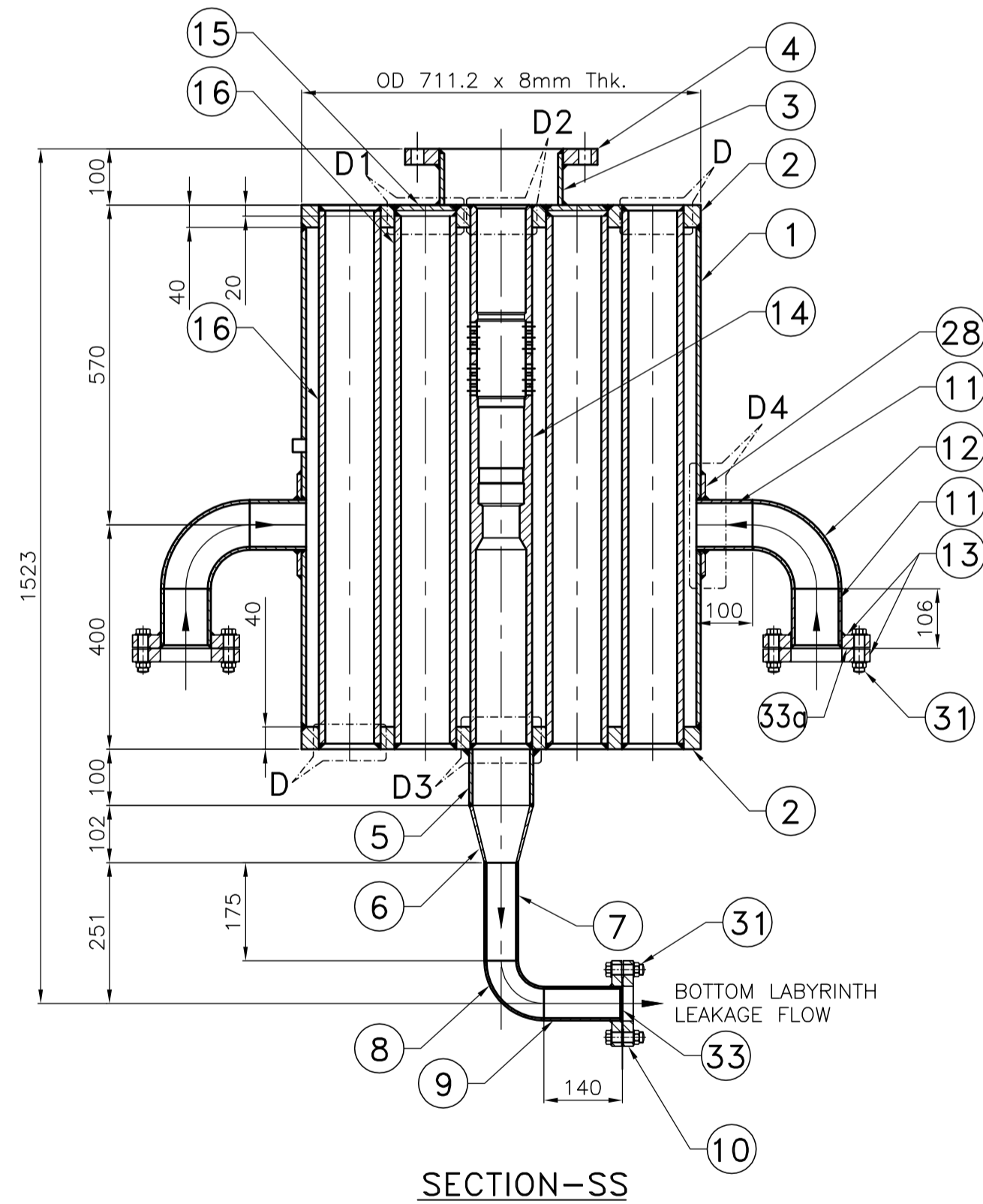

SECTION-SS

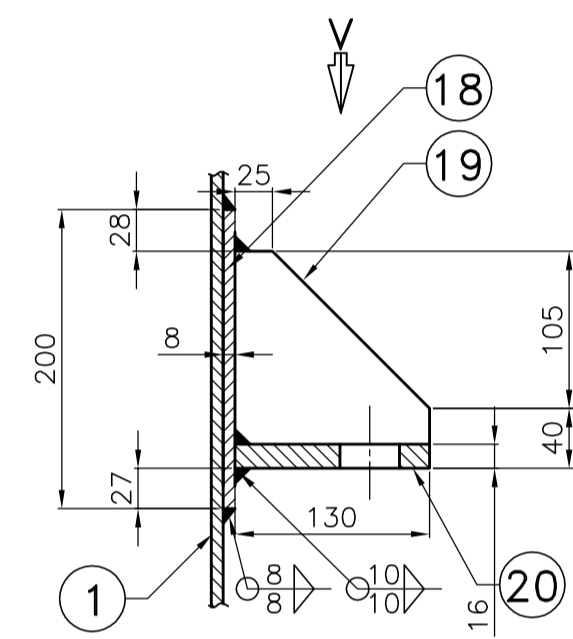

DETAIL-D4
(SCALE-1:5)

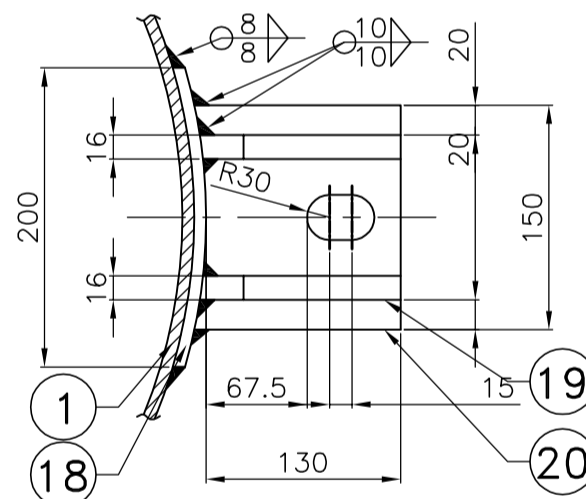

VIEW-V
(SCALE-1:5)

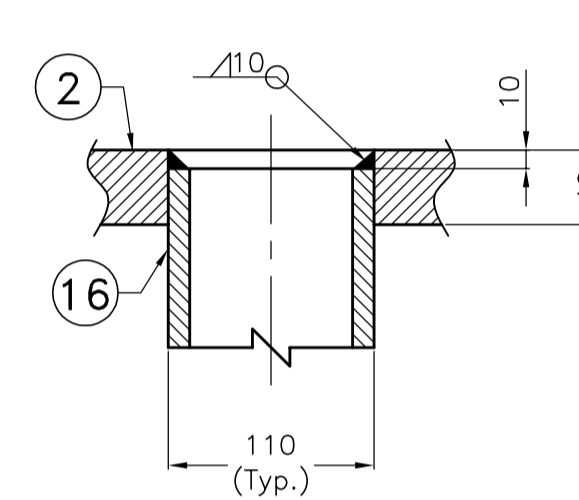

DETAIL-D
(SCALE-1:4)

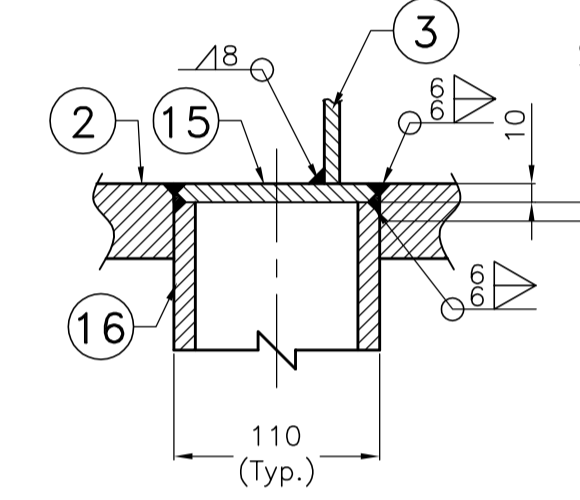

DETAIL-D1
(SCALE-1:4)

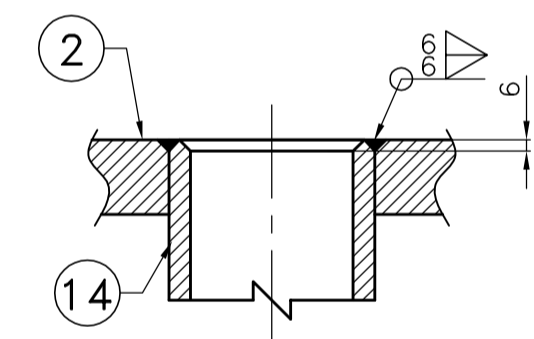

DETAIL-D2
(SCALE-1:4)

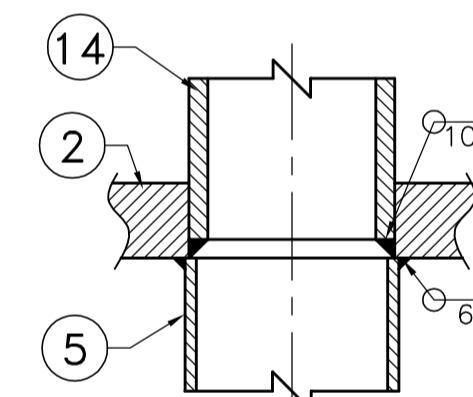

DETAIL-D3
(SCALE-1:4)

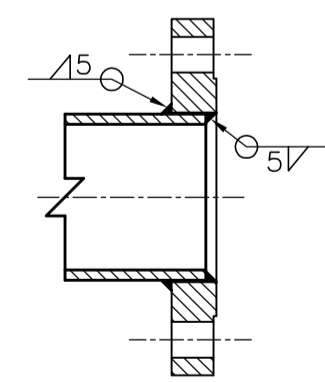

FLANGE TO PIPE WELDING
DETAIL (TYPICAL)
(SCALE-1:4)

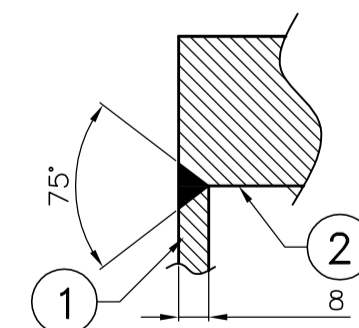

SHELL TO FLANGE WELDING
DETAIL (TYPICAL)
(SCALE-1:2)

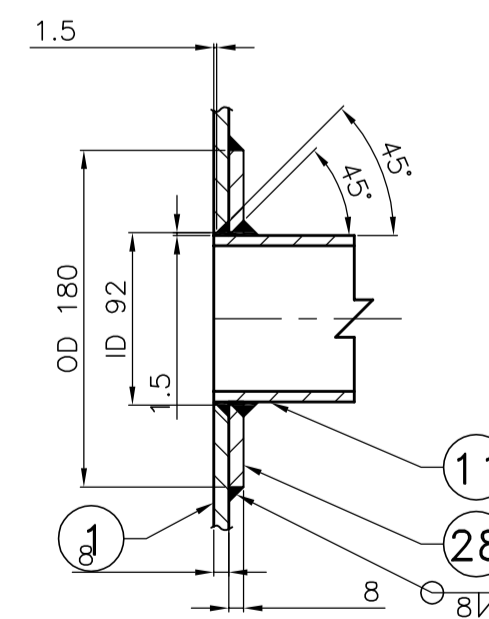

DETAIL-D4
(SCALE-1:4)

NOTES

1. ALL DIMENSIONS ARE IN mm.
2. ELBOW AND REDUCER JOINT ARE BUTT WELDED.
3. FOR BILL OF MATERIAL AND IHX OVERALL ASSEMBLY REFER DRG. NO.

DRG. No. ETHD/HES/99240/DD/3125 SHT. 2 OF 2 P.A.

THIS DESIGN AND DRAWING IS THE PROPERTY OF THE INDIRA GANDHI CENTRE FOR ATOMIC RESEARCH. IT MUST BE RETURNED WITH QUOTATION OR UPON DELIVERY OF MATERIAL AND EQUIPMENT AND MUST NOT BE USED EXCEPT BY THE PERMISSION OF THE OWNER

REFERENCE DRAWINGS	DRG. No.	ISSUE No.	REV. No.	DRAWING RELEASED FOR	SIGNATURE & DATE	MATERIAL	AS PER BOM	GENERAL TOLERANCES
		1	0	FABRICATION		QTY. PER ASSEMBLY	-	LENGTHS : 0 to 50 ± 0.1
						WT. PER PIECE IN Kg.	-	50 to 120 ± 0.2
						HEAT TREATMENT	-	120 to 315 ± 0.3
						SURFACE TREATMENT	-	> 315 ± 0.4
						Min. SURFACE FINISH & OTHER INFORMATIONS	3.2/	LENGTHS : SHAFT h 12
								HOLE H 12

GOVERNMENT OF INDIA
INDIRA GANDHI CENTER FOR ATOMIC RESEARCH
REACTOR DESIGN & TECHNOLOGY GROUP

TITLE
INTEGRATED SA TEST SET UP

ORIGINATING AGENCY: FRIG / ETHD
SCALE: 1:10
PROJECTION:

DRG. No. ETHD/HES/99240/DD/3125 SHT. 2 OF 2 REV. No. A